

# ASSEMBLY INSTRUCTIONS

---

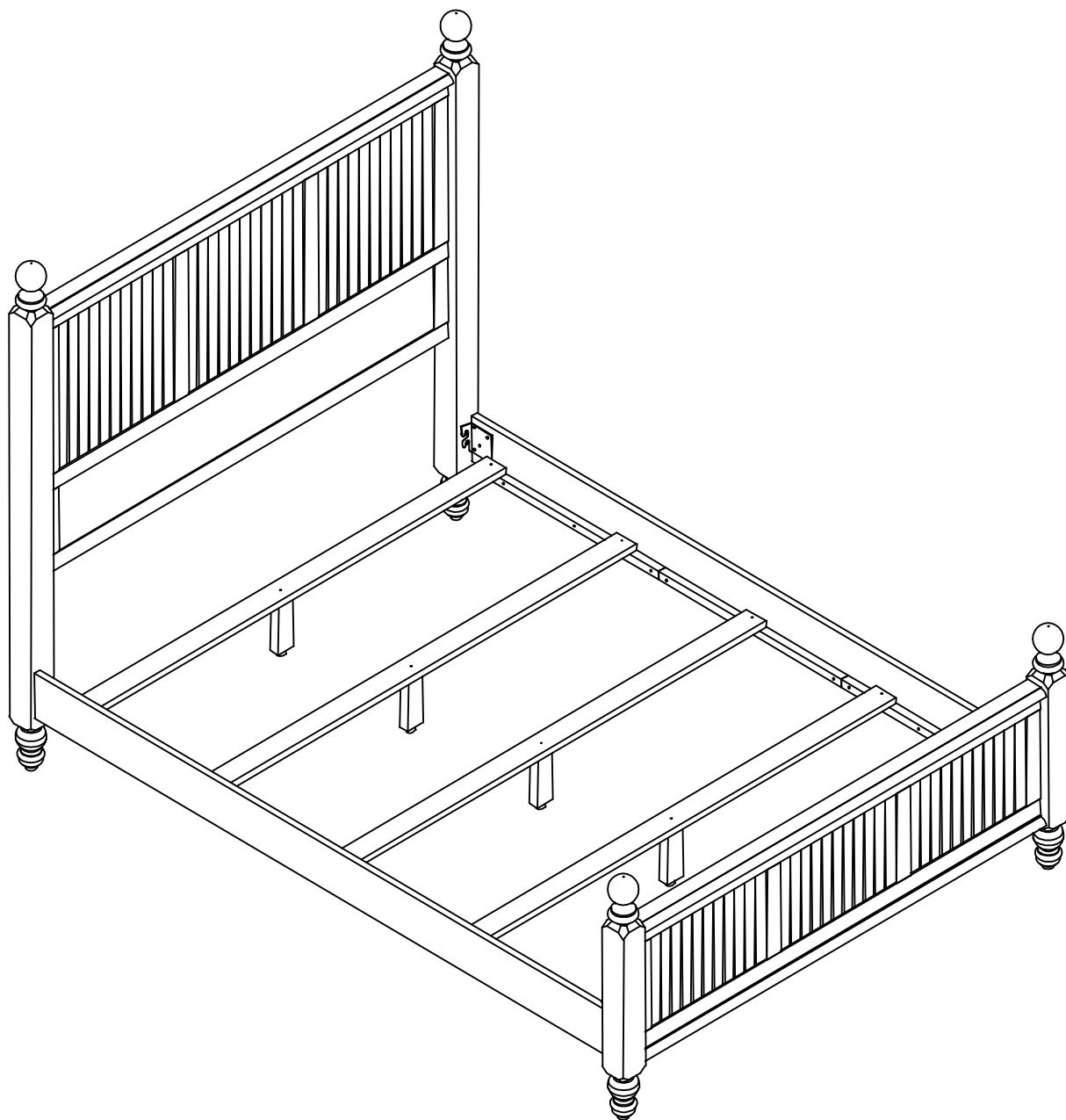

---

Description : QUEEN COTTAGE BED

Item No. :

(PACKED IN SEPARATE BOX)

ITEM NO. :  
ISSUED SEP 04, 2015

Printed in Vietnam

## BEFORE ASSEMBLY

Thank you for purchasing this quality product. This product has been designed for easy assembly and constructed for durability. All parts were checked prior to packaging to insure quality. Prior to beginning assembly, however, make sure all parts and hardware are included and free of obvious defect. If a part is missing or defective, please contact the store where purchased. If hardware is missing, or you need help with assembly, please call toll free 888-944-8396.

### IMPORTANT NOTE:

- Place all wooden parts on a clean and smooth surface such as a rug or carpet to avoid the parts from being scratched.
- Remove all wrapping material, including staples & packing straps before you start to assemble.
- DO NOT tighten all screws and bolts until completely assembled.
- Keep all hardware parts out of reach of children.

### ASSEMBLY TOOLS REQUIRED

NOT INCLUDED

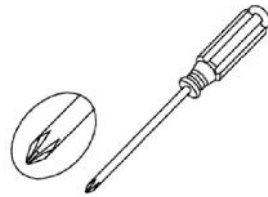

## PART LIST HEADBOARD

When unpacking, please be careful not to discard any parts with the packaging. Before continuing, please make sure you have the following parts:

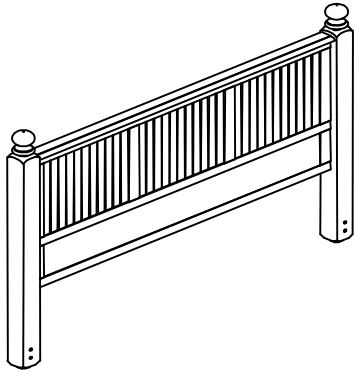
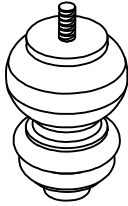
NO	Description	Qty	Sketch
A	Headboard	1	
B	Leg	2	

## PART LIST FOOTBOARD

When unpacking, please be careful not to discard any parts with the packaging. Before continuing, please make sure you have the following parts:

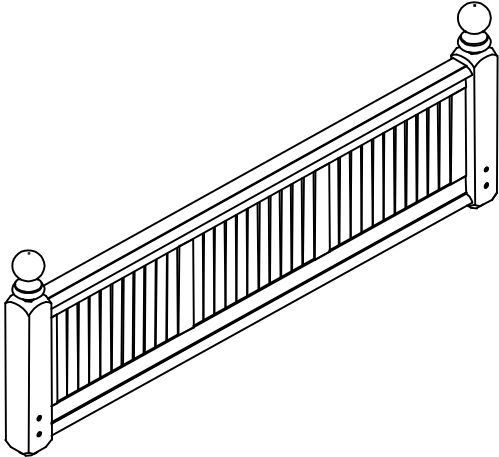
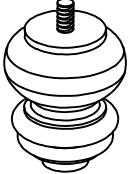
NO	Description	Qty	Sketch
C	Footboard	1	
D	Leg	2	

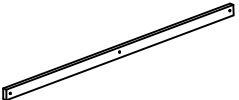
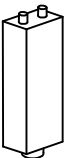

## PART LIST BD-504QR

When unpacking, please be careful not to discard any parts with the packaging. Before continuing, please make sure you have the following parts:

NO	Description	Qty	Sketch	NO	Description	Qty	Sketch
E	Side Rail	2		F	Slat	5	
G	Support Leg	5					

## HARDWARE LIST

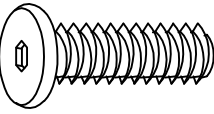
When unpacking, please be careful not to discard any parts with the packaging. Before continuing, please make sure you have all of the following hardware (in box of siderails and slats):

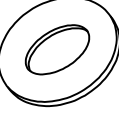
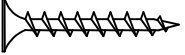
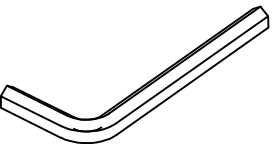
NO	Description	Qty	Sketch	NO	Description	Qty	Sketch
1	Bolt (M8x25mm)	8		2	Lock washer (M8.5x13mm)	8	
3	Flat washer (M8.5x19mm)	8		4	Wood screw (M4x35mm)	15	
5	Allen key (M4x80mm)	1					

**NOTE: HARDWARE IS PACKED IN CARTON BD-504QR**

# STEP 1

Attach legs (B) to headboard (A), as shown below.  
Attach legs (D) to footboard (C), as shown below.

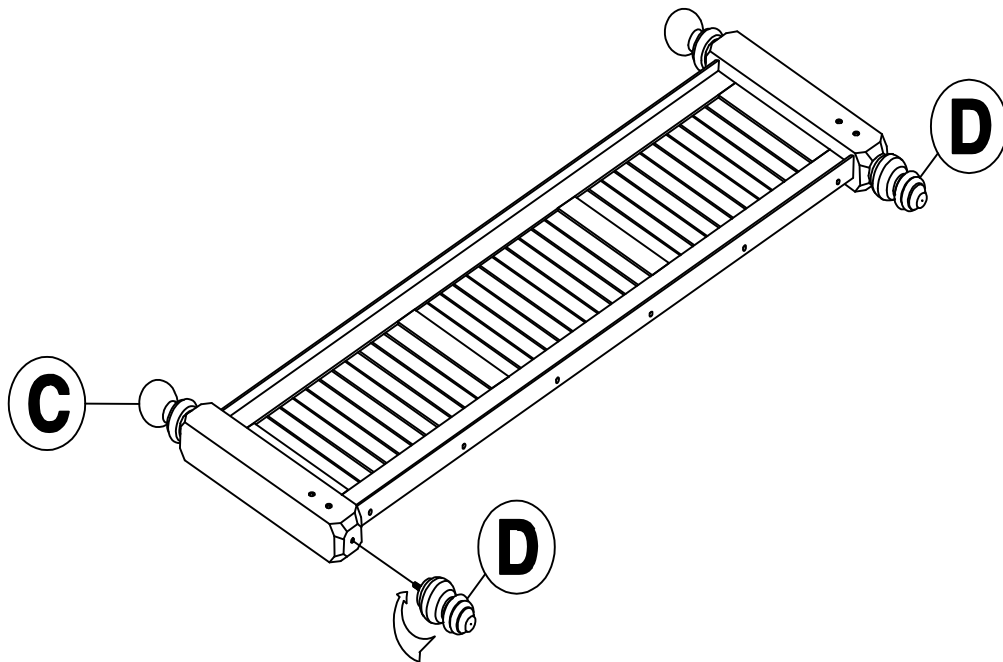
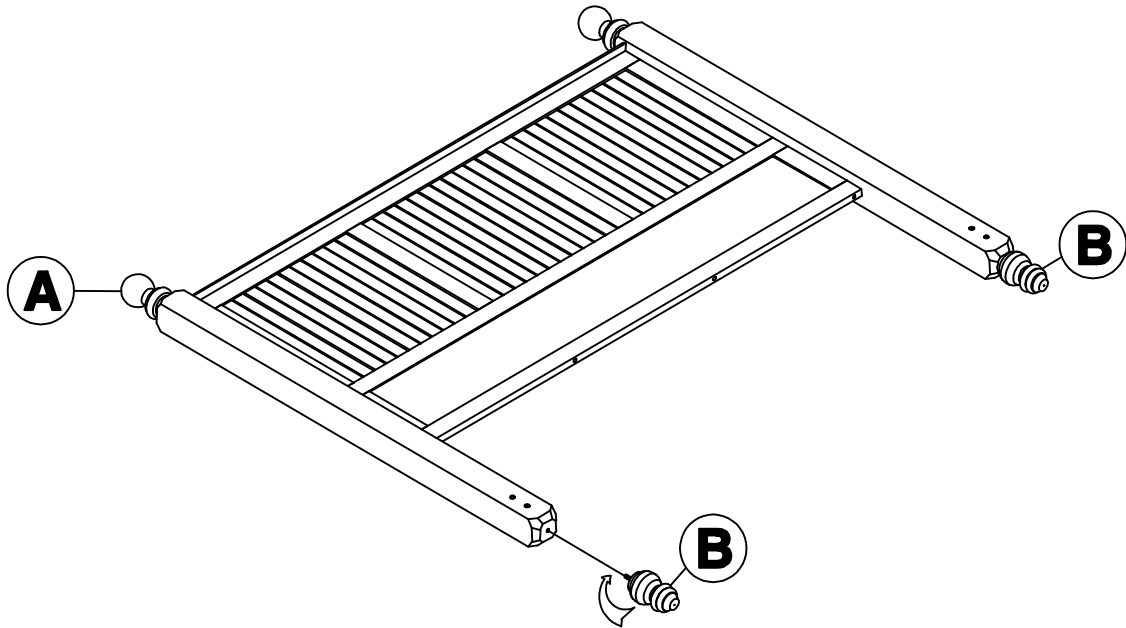

## STEP 2

Attach side rails (E) to headboard (A) and footboard (C) with bolts (1) and washers (2) and (3), as shown below. Tighten with Allen key (5).

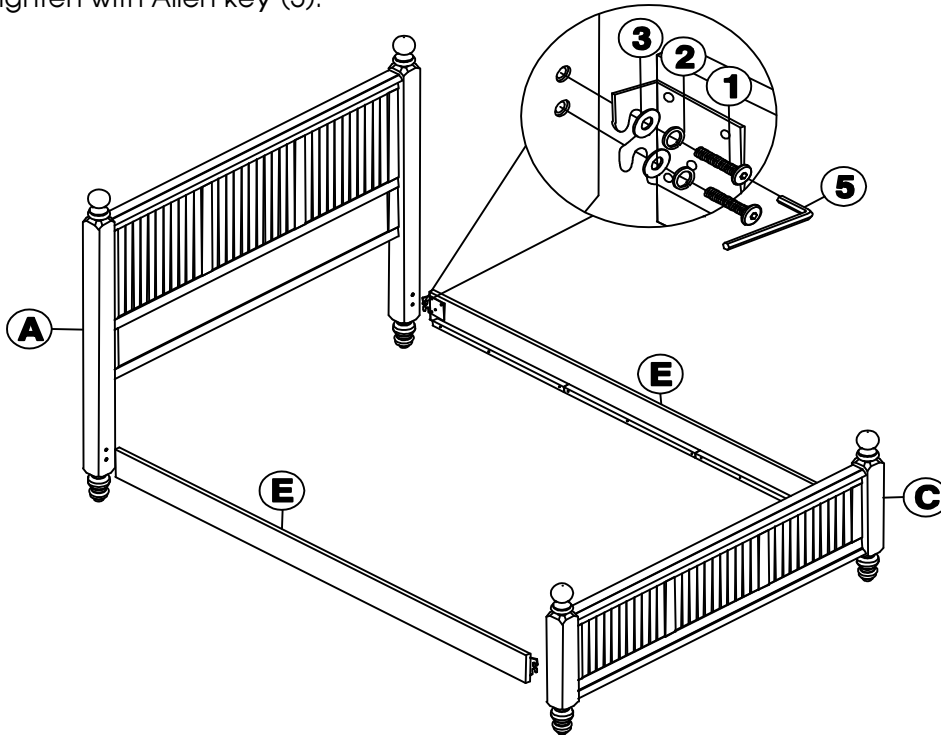

## STEP 3

Attach support legs (G) to slats (F) with screws (4). Tighten with a screwdriver.  
Attach slats (F) to side rails (E) with screws (4). Tighten with a screwdriver.

