

# ASSEMBLY INSTRUCTIONS

---

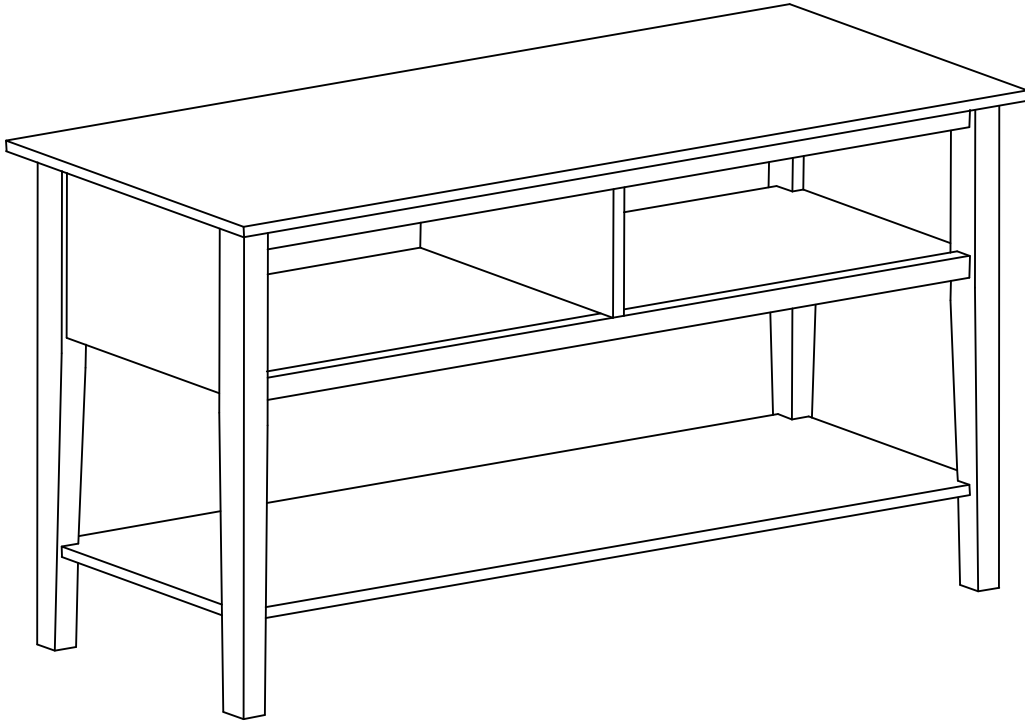

---

Description : 60 IN TV STAND  
Item No. : TV - 8

## BEFORE ASSEMBLY

Thank you for purchasing this quality product. This product has been designed for easy assembly and constructed for durability. All parts were checked prior to packaging to insure quality. Prior to beginning assembly, however, make sure all parts and hardware are included and free of obvious defect. If a part is missing or defective, please contact the store where purchased. If hardware is missing, or you need help with assembly, please call toll free 888-944-8396.

**IMPORTANT NOTE:**

- Place all wooden parts on a clean and smooth surface such as a rug or carpet to avoid the parts from being scratched.
- Remove all wrapping material, including staples & packing straps before you start to assemble.
- DO NOT tighten all screws and bolts until completely assembled.
- Keep all hardware parts out of reach of children.

**WARNING:**

Long exposure to rubber or soft plastic may cause a chemical reaction and damage the finish of your product. Protect the surface of the product with cloth if you are using any product with rubber feet or base.







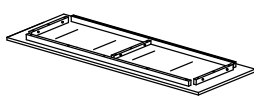
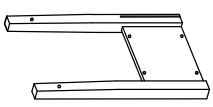
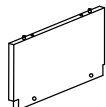
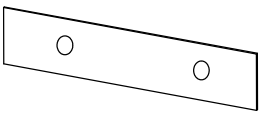
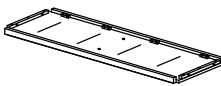
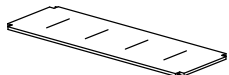

## PART LIST

When unpacking, please be careful not to discard any parts with the packaging. Before continuing, please make sure you have the following parts.

NO	Description	Qty	Sketch	NO	Description	Qty	Sketch
<b>A</b>	Top	1		<b>B</b>	Side panel (L - R)	2	
<b>C</b>	Vertical panel	1		<b>D</b>	Back panel	1	
<b>E</b>	Bottom panel	1		<b>F</b>	Shelf	1	

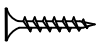
# HARDWARE LIST

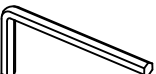
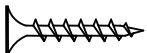
When unpacking, please be careful not to discard any parts with the packaging. Before continuing, please make sure you have all of the following hardware:

NO	Description	Qty	Sketch	NO	Description	Qty	Sketch
1	Bolt (M6x35mm)	12		2	Lock Washer (Φ6.5 x 11mm)	12	
3	Flat Washer (Φ6.5 x 19mm)	12		4	Screw (M3.5 x 15mm)	12	
5	L - Bracket	4		6	Allen key (M4x80mm)	1	
7	Screw (M4 x 35mm)	2		8	Steel band	2	

## STEP 1

Attach vertical panel (C) to top (A) with bolts (1), and washers (2) and (3) as shown below. Tighten with Allen key (6).

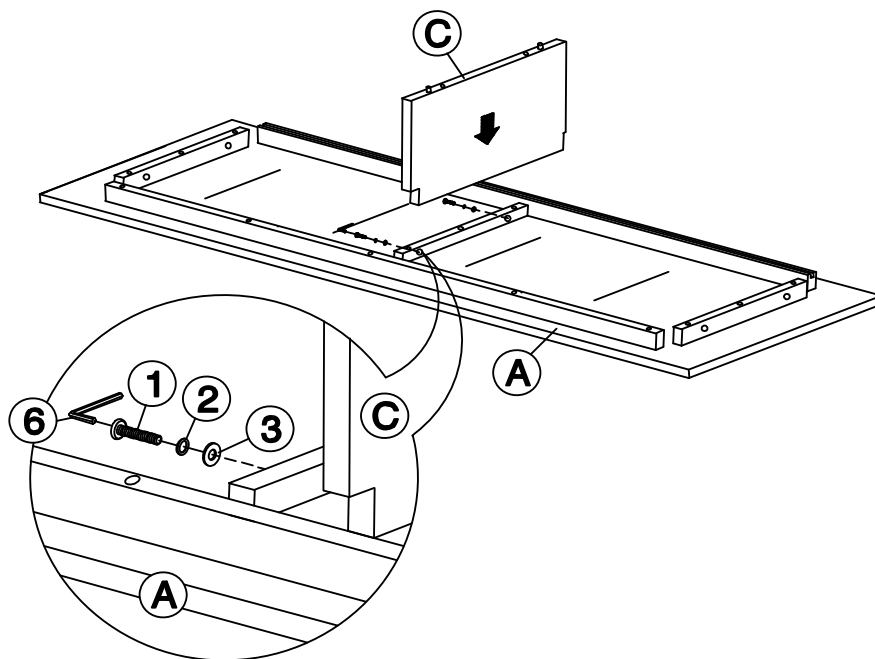

## STEP 2

Slide the back panel (D) into the grooves as shown below.

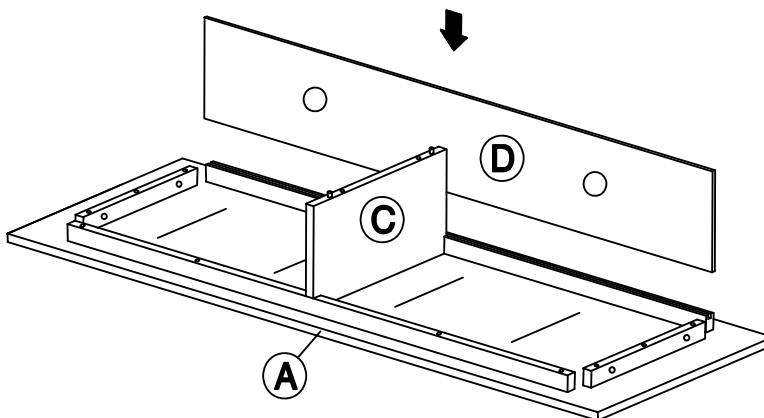

## STEP 3

Attach bottom panel (E) to vertical panel (C) with bolts (1), and washers (2) and (3) as shown below. Tighten with Allen key (6).

Then attach side panel (B) to top (A) and bottom panel (E) with bolts (1), and washers (2) and (3). Tighten with Allen key (6).

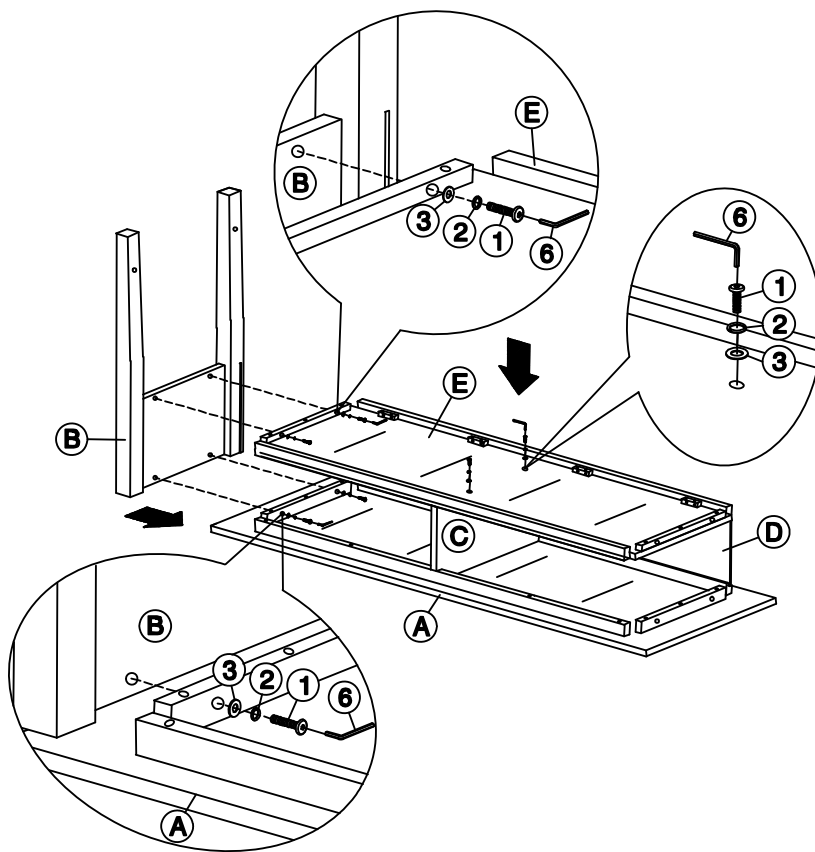

## STEP 4

Insert shelf (F) into the hole on the side panel (B) as shown below. Then attach side panel (B) to top (A) and bottom panel (E) with bolts (1), and washers (2) and (3). Tighten with Allen key (6).

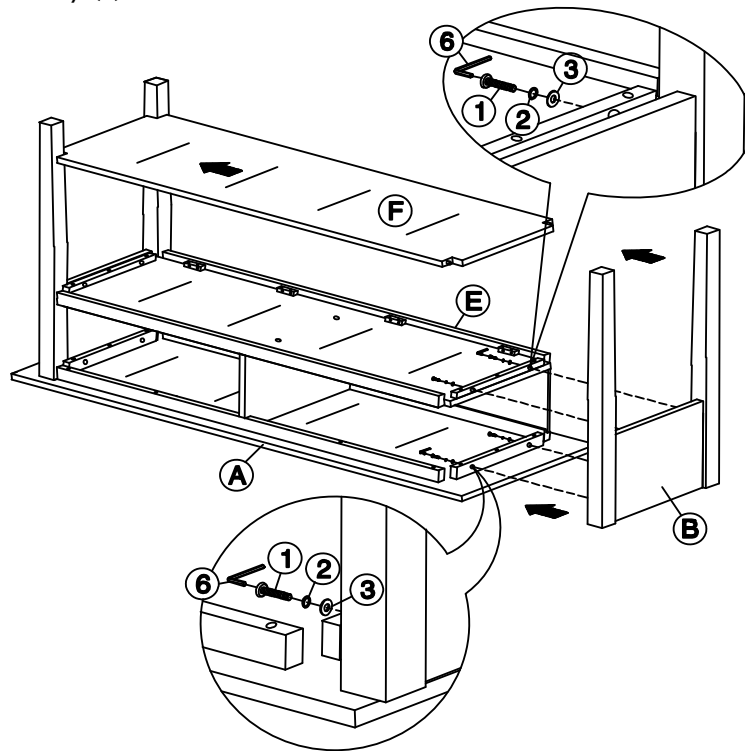

## STEP 5

Attach shelf (F) to side panel (B) with L-Brackets (5) and screws (4) as shown below. Tighten with a screwdriver.

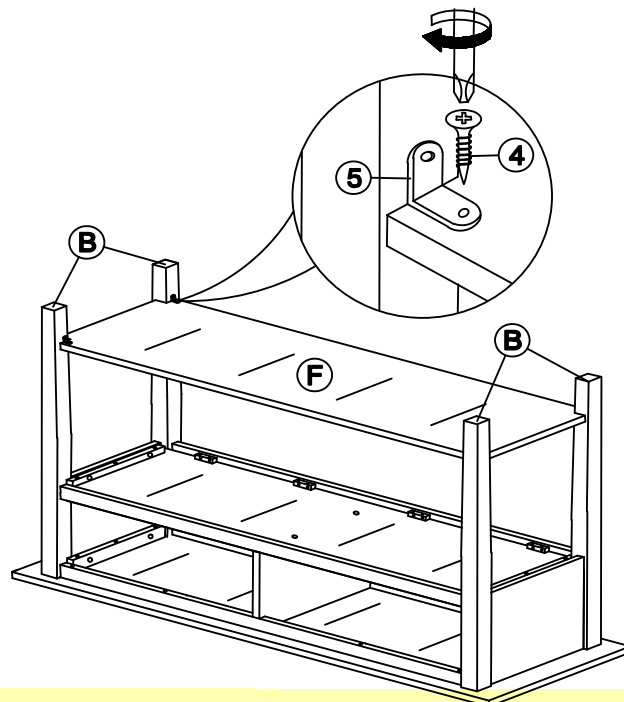

## STEP 6

Attach steel bands (8) to the unit with screws (4) and attach steel bands (8) to the wall with screws (7) as shown below (to secure the product and prevent tipping). Tighten with a screwdriver.

